

Fit the Autoflush solenoid valve in parallel with the Manual Flow Restrictor Valve, as shown.

Depending on which setting the controller is set to the system will either Autoflush every hour or Autoflush just once at the start of filling.

The system will fill automatically as long as the tank is not already full. Filling will activate the Autofill solenoid valve allowing water to fill the tank until the level switch detects that the tank is full.

The controller constantly monitors the Dead End detection and Low Battery protection while in fill mode to protect your system.

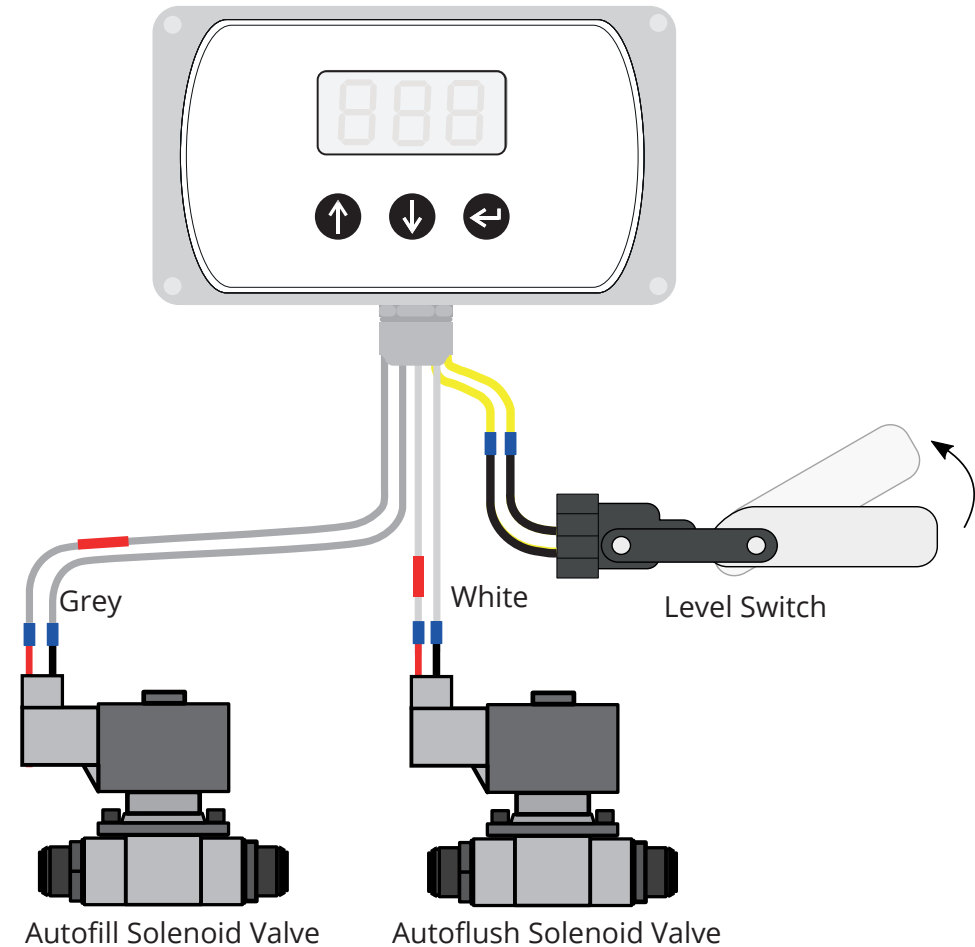

Connect the solenoid valves and level switch in accordance with this diagram. Wire the Autofill solenoid valve using the grey controller wires and the Autoflush solenoid valve using the white controller wires. The level switch should then be connected using the yellow controller wires.



**The Fuse for this unit is a 10A Fuse. Make sure correct fuse is fitted inline, close to the battery end of the RED (positive) wire. Failure to do so will result in damage to the unit.**

If configured, your controller can have two filling modes:

1. One time fill (stops when the level switch activates/lifts)
2. Fill on demand (refills every time the level switch drops)

To select the required filling mode press and hold the down and enter buttons. The controller will display the fill on demand (FOd) menu.



Press up or down to change between on and off. Off will set the controller to 'one time fill'. On will set the controller to 'fill on demand'.

Press enter to set. The next setting is Fill Delay.



Fdy is the time delay in minutes from the tank reaching full and the filling re-starting should the water level drop. You can set this delay from 0-10 minutes with the up and down buttons. Setting to '0' turns the delay off. Press enter to set.



The next setting is Autoflush. Your controller has three Autoflush modes:

- 0 - Autoflush is off
- 1 - Repeat Autoflush every hour
- 2 - Autoflush just once at the start of filling

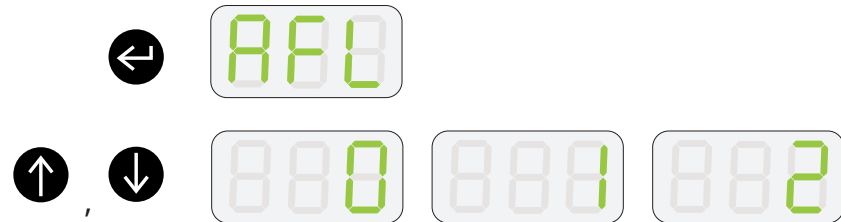

Select the required Autoflush mode with the up or down button. Then press enter to move to the next item.

To enable or disable the Low Battery cutoff (that stops your pump when the battery voltage is below 10.5V) press the down and enter buttons together. Then use the up or down button to change the setting and press enter to set.



NOTE: 'ON' keeps your battery protected\*.

To start filling the tank press and hold the up and down buttons. This will activate the solenoid valve allowing water to fill the tank until the float switch detects that the tank is full.



The tank can be filled when the unit is on (even when pumping) or when the unit is turned off. While the solenoid valve is on and the tank is filling, the display will flash FIL.



To manually stop the tank filling press and hold the up and down buttons again. The display will stop showing FIL.



Fill on demand is effectively a tank level control that keeps the tank topped up to the level switch. The solenoid valve will be turned off if the unit detects a low battery (below +10.5V).

**\* Your battery is at risk of permanent damage if you disable low battery cutoff and continue to use your controller for long periods when the battery voltage has fallen below +10.5V.**

DISCLAIMER  
THE MANUFACTURER RESERVES THE RIGHT TO MAKE CHANGES TO ANY PRODUCT HEREIN TO IMPROVE RELIABILITY, FUNCTION OR DESIGN. THE MANUFACTURER DOES NOT ASSUME ANY LIABILITY ARISING OUT OF THE APPLICATION OR USE OF ANY PRODUCT OR CIRCUIT DESCRIBED HEREIN.

For more information and videos on how to use Spring controllers please visit: [www.springltd.co/videos](http://www.springltd.co/videos)