

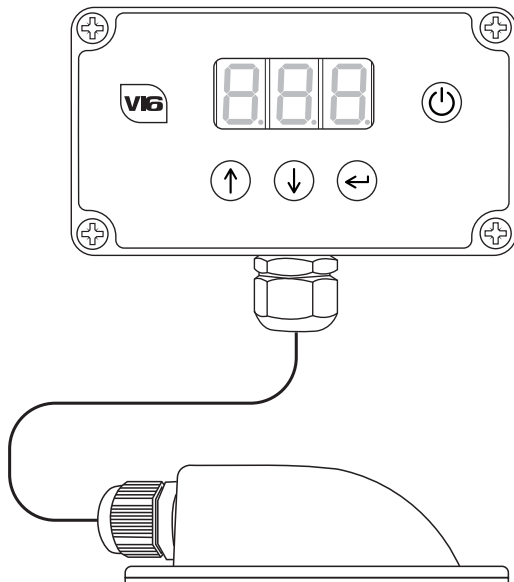

Lumi-Level Additional Wiring



Connect the pump controller in accordance with this diagram.
NOTE: only fit the fuse once all connections are made.



The Fuse for this unit is a 10A Fuse. Make sure correct fuse is fitted inline, close to the battery end of the RED (positive) wire. Failure to do so will result in damage to the unit.

The Lumi-Level will need to be wired before use. To do this feed the grey LLS cable from the controller through the enclosure gland, as seen in the diagram below.

Important: Ensure the Lumi Level is wired before connecting the pump controller to the battery.

Before wiring always ensure the controller is not connected to the power supply. Place the red wire into the +12V terminal and tighten the terminal screw. Repeat for the blue wire into the Out terminal and the black wire into the 0V terminal, as seen below.

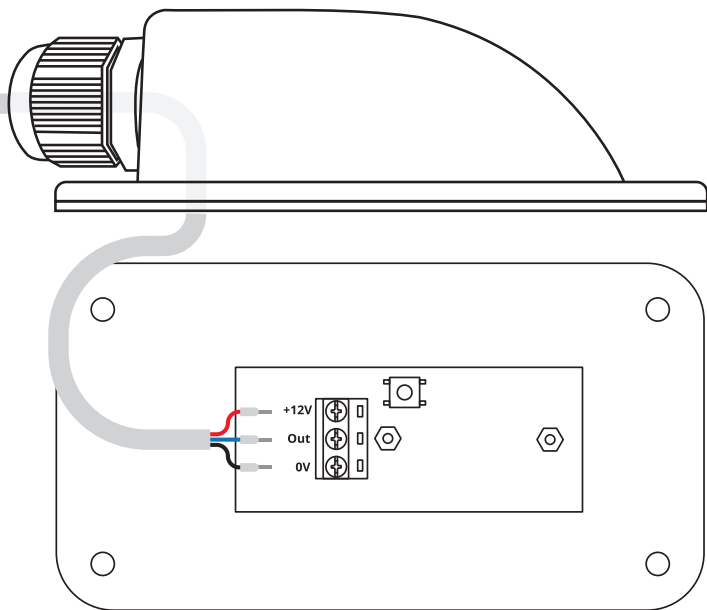

The switch on the Lumi-Level is for the manufacturers calibration only.

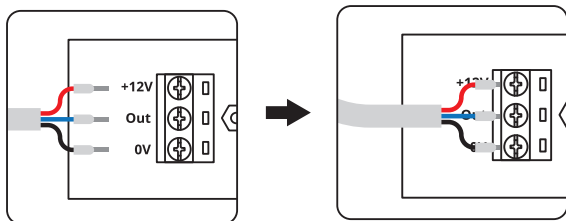

Ensure correct polarity when wiring the Lumi-Level. Failure to do so could result in damage to the unit. If wired incorrectly the unit will not work.

Lumi-Level Placement

The Lumi-Level should be fitted to the top of the tank. It should be placed with the full height of the tank below it. Be aware of any baffles or notches in the tank as this will affect the Lumi-Level's reading.

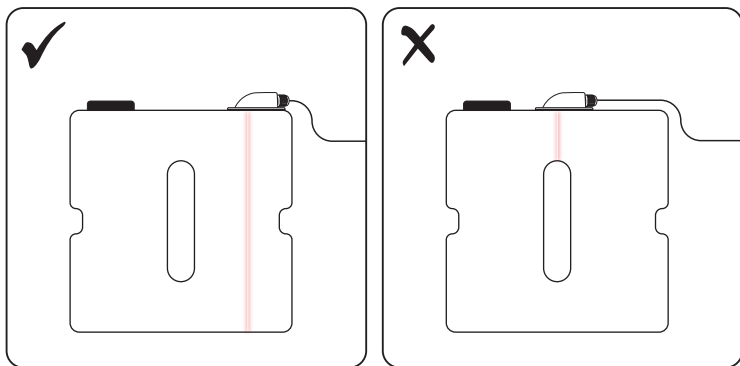

Cut around the drilling template, secure to the top of the tank and drill holes. See Placement Instructions for details on placement. Whilst drilling, prevent swarf from falling into the tank.

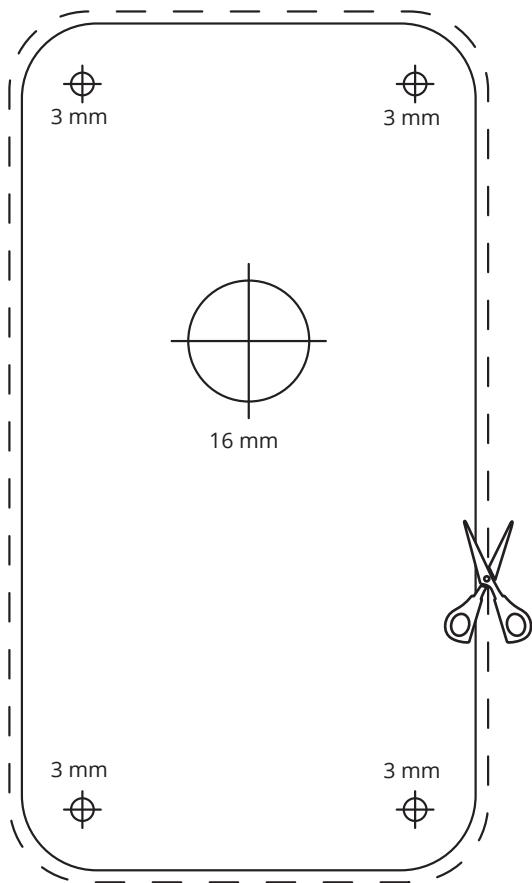

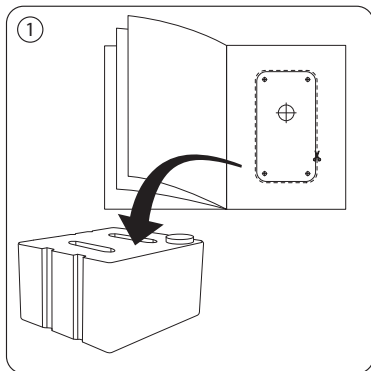

1 Cut out the drilling template from this manual and attach to the top of the tank following the placement instructions.

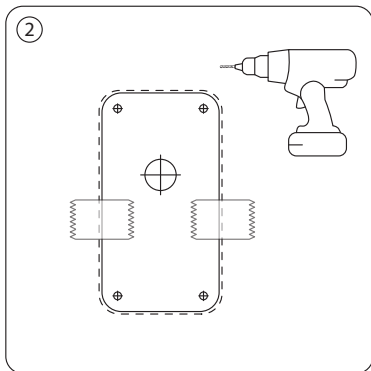

2 See drilling template for hole sizes. When drilling, prevent the swarf from falling into the tank to avoid any damage to the system.

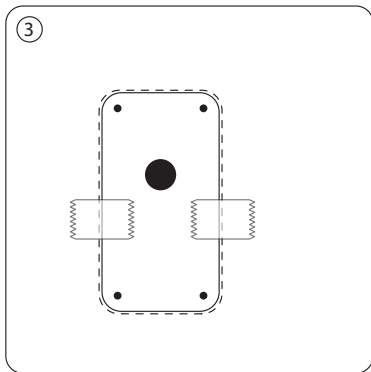

3 Once the holes are drilled, remove the template and smooth off any rough edges.

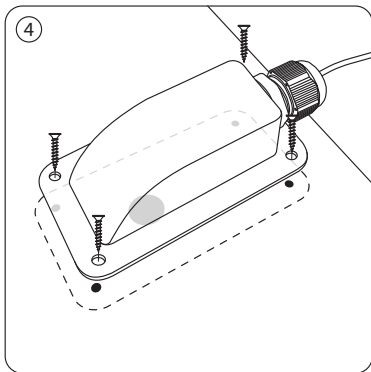

4 Place the Lumi-Level over the drilled holes, making sure the laser aperture is in the correct orientation, then fasten with screws provided.



To calibrate the Lumi-Level to the tank press and hold the down and enter buttons and follow these steps.

IMPORTANT: Ensure tank is level when making all measurements.

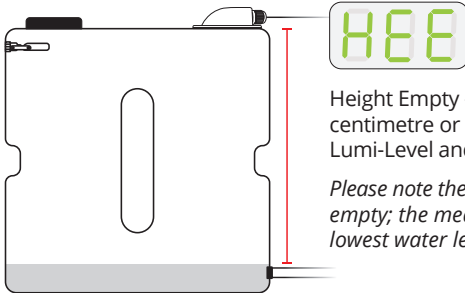

Height Empty - Enter the dimension (nearest centimetre or 1/2 of an inch) between the Lumi-Level and the lowest level of the water.

Please note the tank will never be completely empty; the measurement should be to the lowest water level.

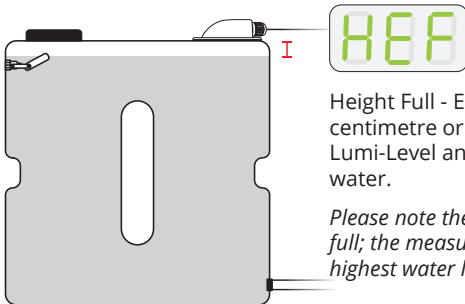

Height Full - Enter the dimension (nearest centimetre or 1/2 of an inch) between the Lumi-Level and the highest level of the water.

Please note the tank will never be completely full; the measurement should be to the highest water level.

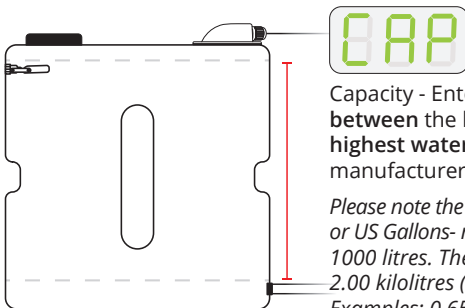

Capacity - Enter the capacity of the tank **between the lowest water level and the highest water level.** Note this is **not** the manufacturer's stated capacity.

Please note the capacity is measured in kilolitres or US Gallons- model dependent. 1.00 kilolitre is 1000 litres. The maximum capacity input is 2.00 kilolitres (2000 litres) or (264 Gallons). Examples: 0.65 = 650 litres | 0.30 = 300 litres

Press enter to monitor the water level (in litres or US gallons - model dependant). LEL will be displayed followed by the reading.



This will show in litres from 0 - 999 and then kilolitres from 1.00 - 2.00 (or US gallons)

For example:



= 562 Litres
(148 Gallons)



= 1030 Litres
(272 Gallons)

If the tank is mounted in a vehicle, allow 1-2 minutes for the water to settle after the vehicle has stopped before reading the level.

NC indicates the Lumi-Level is not connected.



Err indicates a level sensor error. Restart unit by disconnecting and reconnecting power. If message continues contact distributor.



Lumi-Level Operator Warnings

The Lumi-Level will work best when it is calibrated accurately.

Note: Level reading is affected by vehicle vibrations. For an accurate reading make sure the tank is as level as possible.

Do not cover the laser aperture. Follow the drilling template when drilling into the tank and wear proper safety equipment whilst doing so.

Prevent swarf from falling into the tank when drilling as this could cause a blockage in the system or cause damage to the pump.





DISCLAIMER

THE MANUFACTURER RESERVES THE RIGHT TO MAKE CHANGES TO ANY PRODUCT HEREIN TO IMPROVE RELIABILITY, FUNCTION OR DESIGN. THE MANUFACTURER DOES NOT ASSUME ANY LIABILITY ARISING OUT OF THE APPLICATION OR USE OF ANY PRODUCT OR CIRCUIT DESCRIBED HEREIN.

For more information and videos on how to use Spring controllers please visit: www.springltd.co/videos

Copyright © 2021 Spring (Europe) Ltd. All rights reserved.

European Patent: 3835575
VERSION 1.0 RELEASE 14.06.24