

Operating Warnings



The Link2 Receiver is supplied with the mains wire fitted. All other connections require wiring. Fit your Link2 Receiver unit carefully in accordance with the diagrams and following these instructions*.

Always disconnect the Link2 Receiver from power before wiring. The pairing button is situated on the controller's PCB. Once paired always replace the front cover and tighten screws.

Receiver - Specification	Value
Supply Voltage DC	6-36 VDC
Supply Voltage AC	100-230VAC
Power	1W
Fuse Rating DC	1A (on red wire)
Fuse Rating AC	3A (in plug)
Max Load Standard Current	Loads 1, 2, 3 & 4 - 10A
Max Load High Current	Loads 1 & 2 - 20A, 3 & 4 - 10A
Enclosure Material	ABS
Water Resistance	IP65
Dimensions	160 x 118 x 76 (mm)
Working Temperature	0 to 40 Deg C
Link2 - Range	300m (approx**)

* Unit must be installed by a competent electrician or electrical engineer. Failure to comply with these instructions could invalidate your warranty.

** All range distances are line of sight and approximate. Working distances may vary depending on obstacles, environmental conditions and individual installation.

DISCLAIMER

THE MANUFACTURER RESERVES THE RIGHT TO MAKE CHANGES TO ANY PRODUCT HEREIN TO IMPROVE RELIABILITY, FUNCTION OR DESIGN. THE MANUFACTURER DOES NOT ASSUME ANY LIABILITY ARISING OUT OF THE APPLICATION OR USE OF ANY PRODUCT OR CIRCUIT DESCRIBED HEREIN.

For more information and videos on how to use Spring controllers please visit: www.springltd.co/videos

Link 2 is a registered trademark of Spring (Europe) Ltd. Copyright © 2021 Spring (Europe) Ltd. All rights reserved.

Link2™
RECEIVER

Quick Start Guide

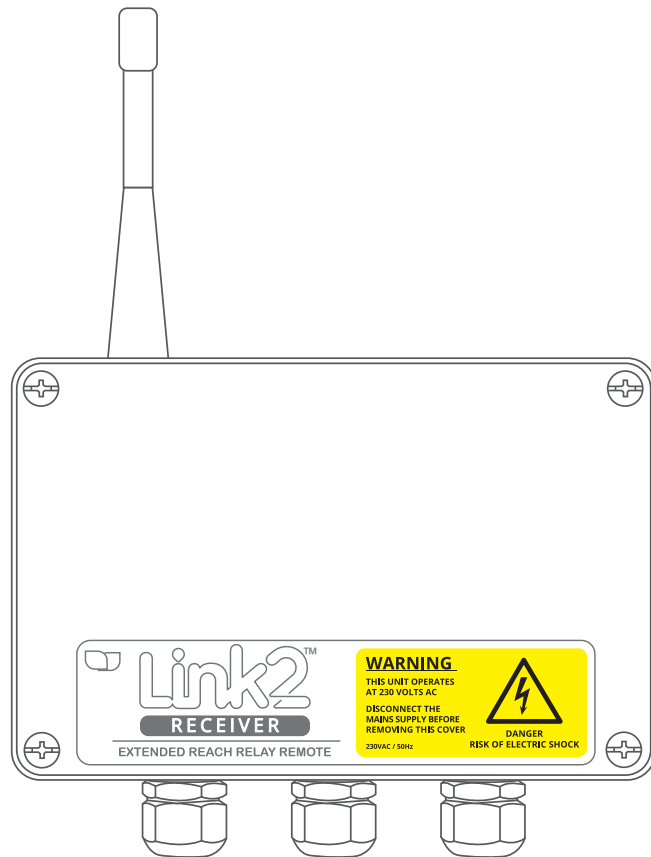

Wiring

The Link2 Receiver can be powered by 6-36VDC or 100-230VAC. It can switch mains powered loads and DC (battery or PSU) powered loads. Follow the diagrams and instructions below for wiring the Link2 Receiver. Note: unit must be installed by a competent electrician or electrical engineer. Failure to comply with these instructions could invalidate your warranty.

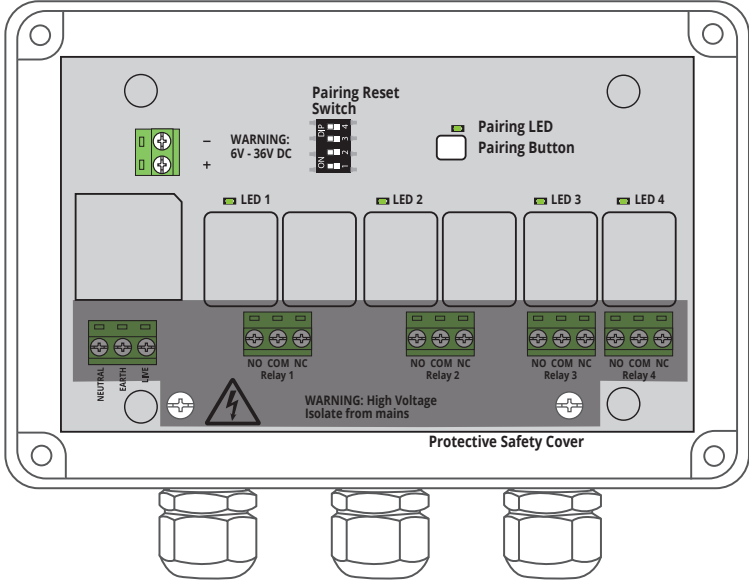

 **Always disconnect power before opening unit.**

Wiring

The Link2 Receiver can be powered by DC or AC. Follow these instructions to wire the unit. Open the enclosure using the four corner screws and remove the protective safety cover using the two screws. Push the wires through the bottom glands and wire accordingly, following these instructions:

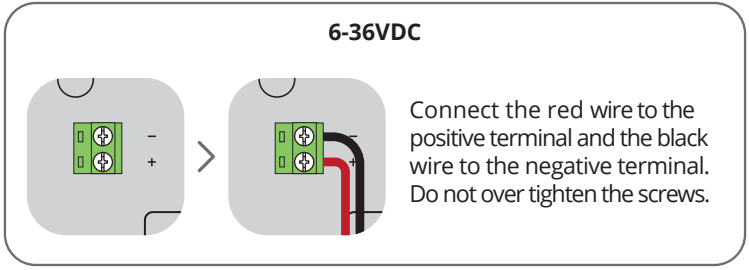

or

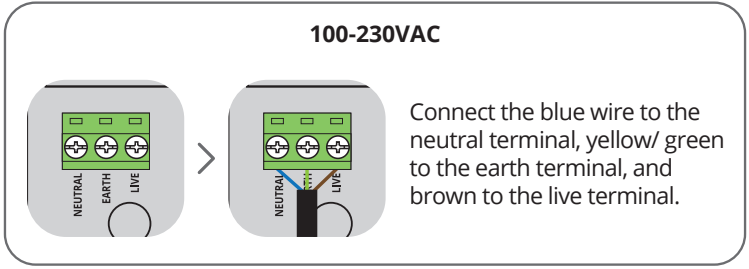

When wiring the loads to the Link2 Receiver unit always disconnect the unit and loads from the power. After wiring tighten glands and **always replace protective safety cover before powering unit.**

The enclosure cover has to be open to pair with the transmitter option. **Once paired replace enclosure cover as soon as possible.**

Operation

To turn on the unit connect to power. Disconnect the power to turn the unit off. Only power the unit when all wiring is complete and the protective safety cover has been replaced.

When the unit has power the Pairing LED will flash slowly. It will then flash quickly to show bonding state with a transmitter and flash slowly again once paired.

Pairing

The enclosure cover has to be open to pair with the transmitter. Extra care should be taken when the unit is powered whilst the enclosure is open. **Once paired replace enclosure cover as soon as possible.**

The Link 2 receiver can be paired with up to five transmitters. To clear all pairings use the Pairing Reset Switch. Switch '1' to the on position for at least five seconds (the switch must then be returned to the off position). When more than five transmitters are paired without clearing, any new pairing will replace the oldest.

For pairing, refer to the transmitter pages of this manual. Always follow the safety instructions.

Manual Override

It is possible to manually override the relay current settings on the Link2 Receiver.

If one or more of the relays are in operation (LEDs are illuminated on the receiver unit) press and hold the receiver pairing button. This will turn off all relays and LEDs.

If none of the relays are in operation (LEDs are not illuminated on the receiver unit) press and hold the receiver pairing button to turn on all the relays (and LEDs). Press and hold again to turn off all the relays (and LEDs).



Transmitters Quick Start Guide

There are four different transmitter options for the Link2 Receiver. Read all instructions and safety warnings before use. Up to five transmitters can be paired with the receiver.

① Rechargeable Fob

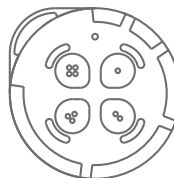

② Non Rechargeable Fob

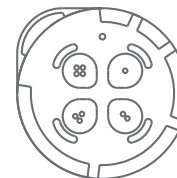

③ Pi Hat Control

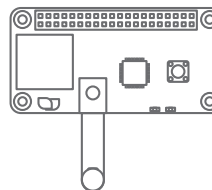

④ Screw Terminal Control

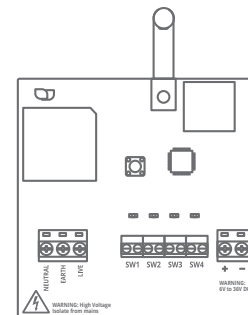

Max Load Currents

There are two versions of the Link2 Receiver. Check unit version before connecting any loads. **Failure to follow maximum load currents could result in damage to the unit.**

The maximum load currents for the Link2 **Standard Current** are:

LOAD 1 10 Amps Max	LOAD 2 10 Amps Max	LOAD 3 10 Amps Max	LOAD 4 10 Amps Max
------------------------------	------------------------------	------------------------------	------------------------------

The maximum load currents for the Link2 **High Current** are:

LOAD 1 20 Amps Max	LOAD 2 20 Amps Max	LOAD 3 10 Amps Max	LOAD 4 10 Amps Max
------------------------------	------------------------------	------------------------------	------------------------------

Each load can be wired to either NO (normally open) or NC (normally closed). Fuses should always be fitted to protect the unit and the wiring. Check the fuse rating in relation to the load current.

Note: All max currents shown are for resistive loads only.

Make sure correct fuses are fitted inline. Failure to do so may result in damage to the unit.

Mains Powered Loads Wiring

Normally open wiring

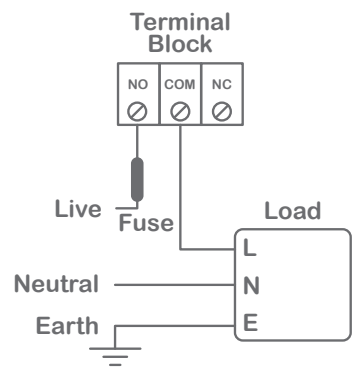

Normally closed wiring

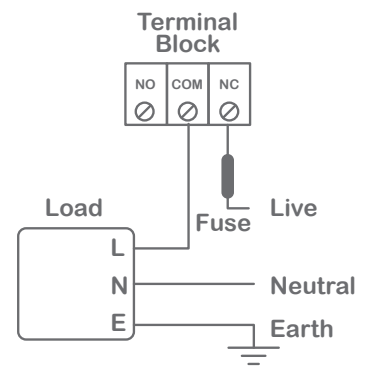

DC Powered Loads Wiring

Normally open wiring

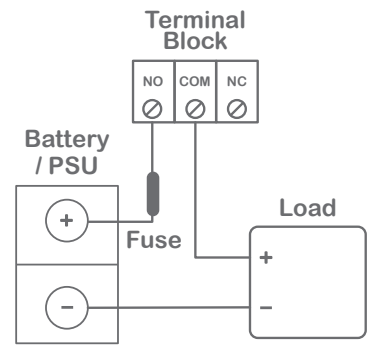

Normally closed wiring

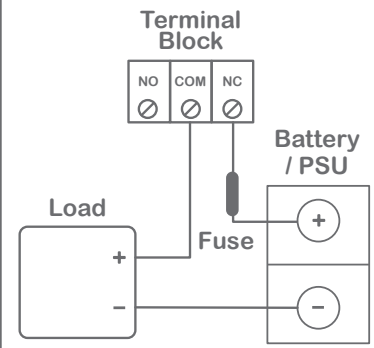



Rechargeable and Non Rechargeable Fobs

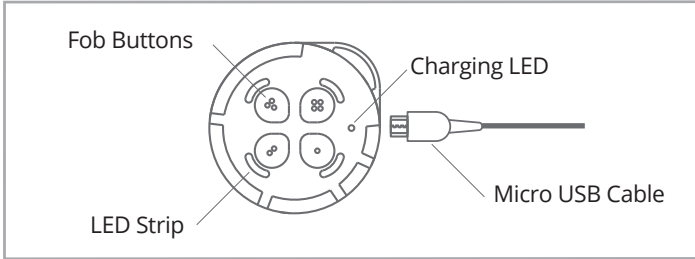

Pairing

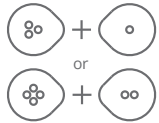

To pair a fob and the Link2 Receiver, press and hold two opposite buttons on the fob. If the fob is charged and working, the LED segments will light up and circle.

The receiver pairing button will flash faster. Press the receiver pairing button.

If pairing is successful, the LED segments will stop circling on the fob and the pairing LED will flash slowly.

Fob Operation



To switch a load, press the button on the fob once. To indicate that the function has worked, the fob LED strip will either fully illuminate or partially illuminate depending on which way the load has been wired (NO or NC).

Fob Charging

Rechargeable Fob

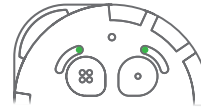

The fob will indicate when it needs charging by lighting two LEDs. To charge, plug in a micro USB charger to the charging connector. The charging LED is red when charging and green when charged.

Non Rechargeable Fob



The charging LED will flash when the fob battery is getting low. When this happens, replace battery with a CR2450 by following the instructions below.

The fob battery can be overridden if needed. To do this, plug a micro USB charger into the charging port. This will only power the fob whilst plugged in and will not recharge the battery.

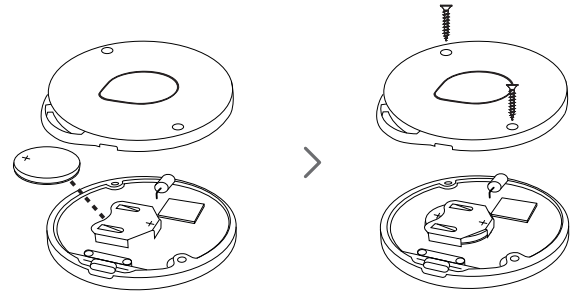

Fob - Specification	Value
Supply Voltage Micro USB Port	5 VDC (300mA)
Supply Voltage Coin Cell	3 VDC (replace with CR2450)
Water Resistance - Fob	IP54 (water resistant)
Dimensions	75 x 16 (mm)

Pi Hat Control

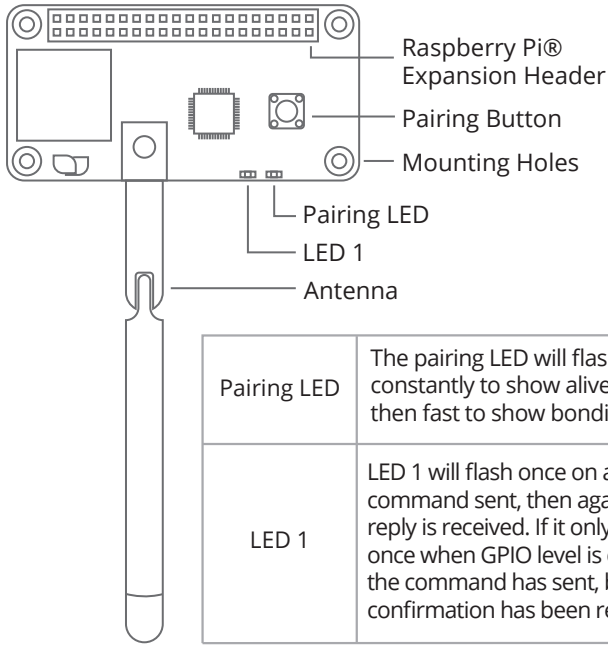

Pairing LED	The pairing LED will flash slowly constantly to show alive state, then fast to show bonding state.
LED 1	LED 1 will flash once on a command sent, then again if reply is received. If it only flashes once when GPIO level is changed, the command has sent, but no confirmation has been received.

 **Always disconnect power before handling unit. Do not expose unit to water, moisture or heat.**

Fob - Specification	Value
Supply Voltage Raspberry Pi®	5 VDC (Raspberry Pi®)
Dimensions (Excl antenna)	64 x 30 (mm)

Assembly

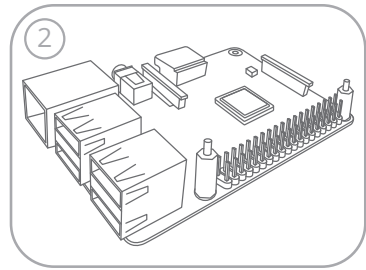
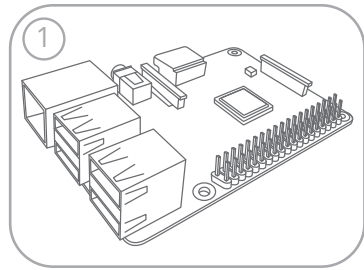

To fit the Pi Hat board to the Raspberry Pi®:

1. The Pi Hat board is compatible with all Raspberry Pi® models. The example shown is a Raspberry Pi 3 Model B V1.2
2. Attach the spacers to the Raspberry Pi®
3. Attach the expansion header to the Pi Hat board and place the Pi Hat board onto the Raspberry Pi® and tighten spacer nuts.

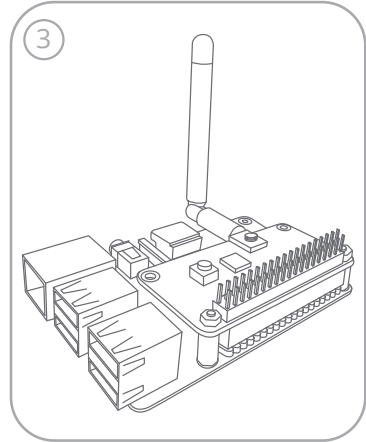

Pairing

To pair the Pi Hat and the Link2 Receiver, press and hold the pairing button on the Pi Hat. Both the Pi Hat pairing LED and receiver pairing LED will flash faster to show bonding

Press the receiver pairing button. If pairing is successful, both pairing LEDs will flash slowly again.

Set GPIO high to turn on the relay on the receiver and low to turn off the relay.

For demo code visit: https://github.com/springltd/link2_pi_demo01

Embedded Control Unit

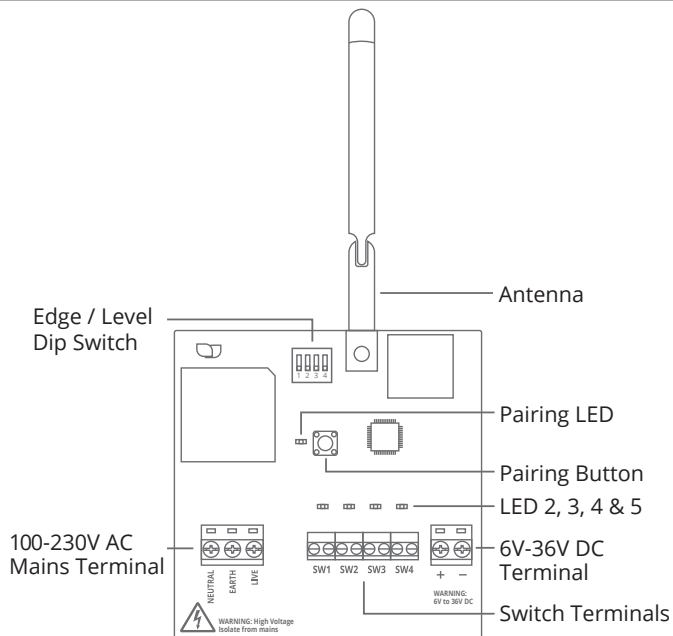

**Always disconnect power before handling unit.
Do not expose unit to water, moisture or heat.**

Fob - Specification

Value

Supply Voltage DC

6-36 VDC

Supply Voltage AC

100-230VAC

Dimensions (Excl antenna)

80 x 80 (mm)

Set Up

The state of the switches can be changed between edge and level using the dip switch. The switches are connected to the corresponding number on the dip switch. In the up position the state is edge and in the down position the state is level.

Wiring

The Embedded Control can be powered by DC **or** AC. Follow these instructions to wire the unit.



6-36VDC

Connect the red wire to the positive terminal and the black wire to the negative terminal. Do not over tighten the screws.

or



100-230VAC

Connect the blue wire to the neutral terminal, yellow/ green to the earth terminal, and brown to the live terminal.

Wire the switches either way round into the switch terminals and tighten the screws.

Pairing

To pair the Embedded Unit and the Link2 Receiver, press and hold the pairing button on the Embedded Unit. Both the Embedded pairing LED and receiver pairing LED will flash faster to show bonding.

Press the receiver pairing button. If pairing is successful, both pairing LEDs will flash slowly again.

Pairing LED

The pairing LED will flash slowly constantly to show alive state, then fast to show bonding state.

LED 2, 3, 4&5

The corresponding LED will flash once when the state of the input changes (edge or level) and then again when confirmation is received from the Link2 Receiver.